

Accessories for your V-Sharp

Mounting to Granite

Remove rubber feet from bottom of unit. Using a coarse sand paper, rough the bottom of the wooden base that will attach to the Granite. Empty approx. 3/4 of the supplied epoxy on the bottom of the wooden base then stir for about 2 minutes. Spread epoxy evenly across bottom then hold in place for 1 minute. Mount unit on one side of Granite (not in the middle). It makes it easier to see which side of the unit you use.

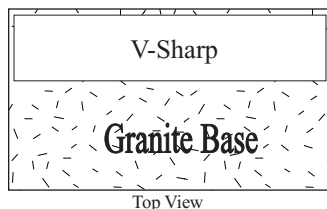

Protective Case



Additional Rods/Steels



Quick Tips

Helpful Hints & Tips *-Not for use with Serrated Edges-*

***Adjusting the Angle** - Leave the unit set up at 25 degrees-your knives will stay sharper longer due to the wide bevel the machine creates. Seventeen degrees is not sharper than 25 degrees. It just has a more delicate edge and tends to dull faster due to the lack of metal supporting the edge.

***Stabilize the Unit** - If you don't have one of our Granite bases, get a small C-Clamp to mount the unit to a workbench or counter top. A 1.5 inch C-Clamp fits inside the Sportsman's Package accessory pocket. We highly recommend mounting the unit to something (clamp, glue or screw) to make it a one handed knife sharpener.

***Leave the Steels in the machine** - the next time you need to sharpen, you can try steeling them to re-align the edge, rather than using the diamonds to resharpen.

***Adjustable Blade Guide** gives you total accuracy when using thick stock blades. Loosen screw on blade guide then either open the gap wider or make it more narrow. For most knives, leave the setting on the middle slot.

***Cleaning the Diamond Rod's** is not necessary. Always use a clean, dry knife through the machine. If diamonds do get an excessive amount of metal in them, use a dry toothbrush to clean.

***Additional Rods** - If you purchased additional diamond rods, make sure you first shape the bevel with the 325 grit that comes in the unit. Then replace the 325 grit with the Rods you purchased to polish and smooth the same edge. Note: Only use the Finishing Stroke with the 600 grit or 1000 grit. Also, you will need to "touch up" your knife more often when using the finer grits.

***Determine the Angle** by using a black magic marker to mark the edge of the blade. Draw the knife through a few times then look to see where the rods are hitting the edge. If you can see where the diamonds are hitting the edge, then begin to sharpen. Otherwise, adjust the machine to a wider angle.

***Test your edge** by gently setting the edge of the blade on a fingernail (preferably the thumb nail). If it catches, it is sharp. If it slides off, pull it through the machine a few more times until it catches on the nail.

www.WarthogSharp.com

Detailed Instructions for the V-Sharp



Register your Product Online to
receive the full benefits of your
3-Year Warranty

www.WarthogSharp.com

Distributed by
Warthog Sharpeners USA, Ft. Lauderdale, FL 33351

1. Setting the "V"

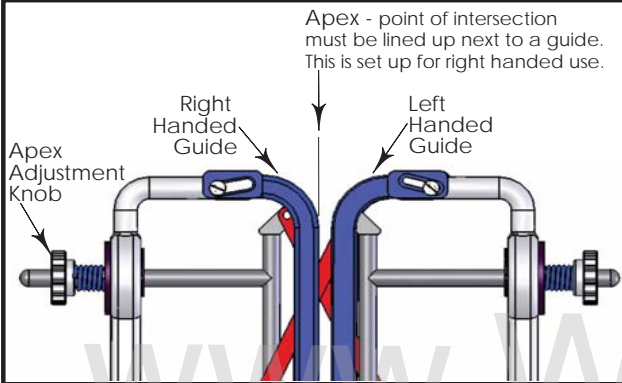

Using the Adjustment Knob, align the apex of the diamond rods to the side you will be using. **Right Handed use the Left Guide**-Keeping the blade *flat* against this guide throughout the entire stroke. **Left Handed use the Right Guide**. By aligning the Apex of the rods next to a guide, you ensure utilizing both rods simultaneously as well as keeping a consistent angle on the knife edge.

4. Using the Steels

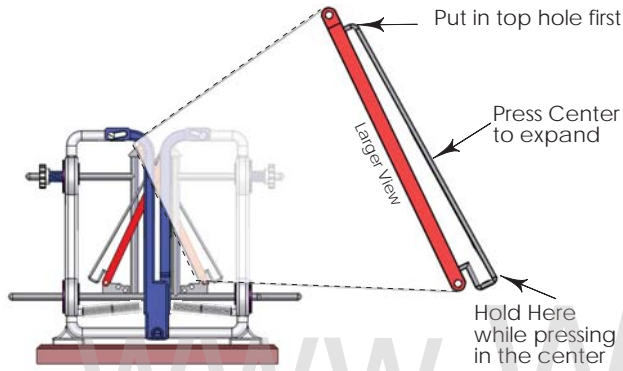

Insert small end of Steels in top hole of diamond rod. While holding the bottom of the Steel, press in the center of the Steel to expand them into the bottom hole. Once both Steels are in place, use the **Finishing Stroke another 5-15 times** - keeping the blade *flat* against the guide. This burnishes the feather edge of a blade to make it razor sharp.

2. Begin Sharpening Sawing/Slicing Motion

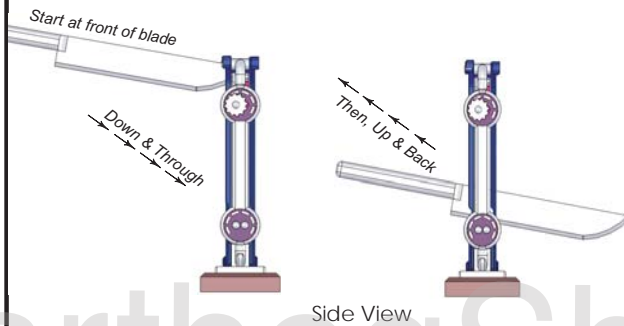

Sawing/Slicing Stroke is only used for initial sharpening. This motion is similar to sawing with a hand saw--it is a rapid down & through; then up & back motion. Do this for approx 15-45 seconds on most kitchen knives and up to 2 minutes on extremely hard steel (D2, 154CM, S30V, etc) Remember to keep the Blade *flat* against the guide without taking it out of the machine.

5. Adjusting the Angles

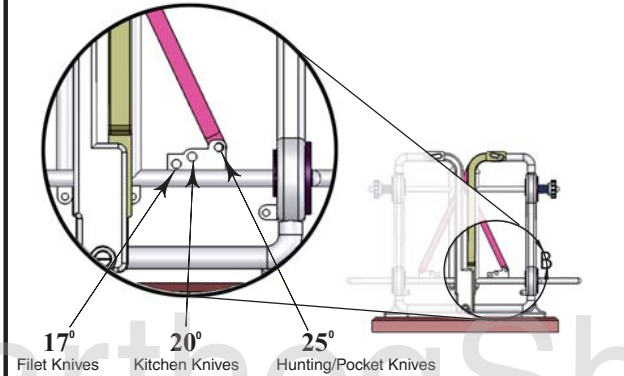

The V-Sharp comes set up at 25 degrees, and is adjustable to 17 degrees or 20 degrees. Simply undo the screw at the bottom and move diamond rod to desired position. Please note: 17 degrees is not sharper than 25 degrees. Twenty-five degrees is just as sharp but has a more durable edge and will stay sharper longer. Seventeen degrees is a much more fragile edge and tends to dull faster.

3. Final Sharpening Finishing Motion

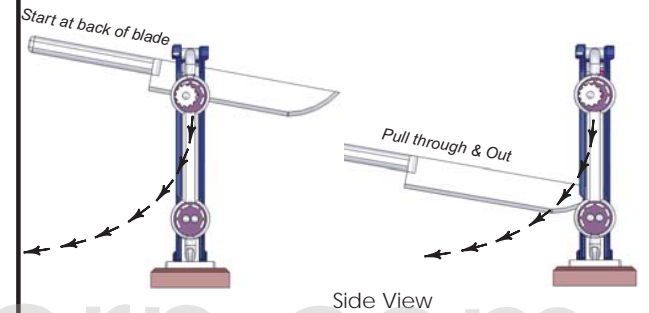

Starting at the back of the blade, pull the knife down and completely out of the machine while keeping the blade *flat* against the guide. Try to get to the bottom of the diamond rods without hitting the bottom. **Do approximately 10-15 strokes. This is the only stroke you will use to touch-up and reshape.** It is not necessary to do the Sawing/Slicing motion once the edge has been established.

Diagram of the V-Sharp

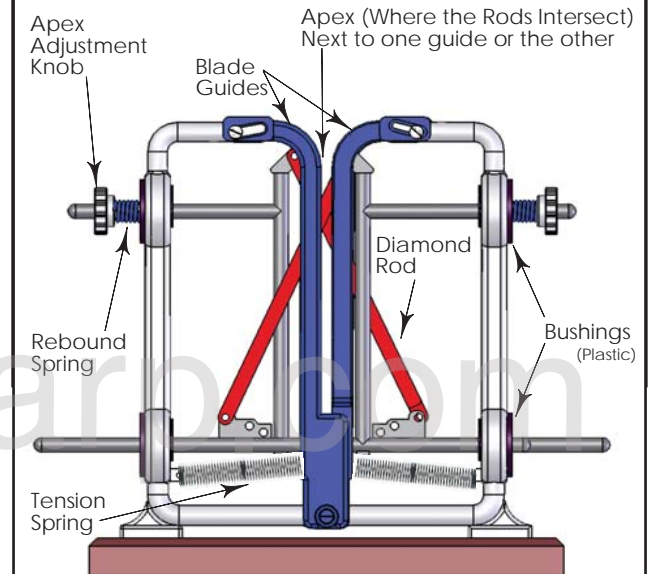

Watch the Instructional Videos Online - www.WarthogSharp.com
(Nothing to download-plays directly from the internet)